

**Installation Instructions for 116DEXMSINH Series  
AdaptaBeacon® Supervised DC Steady-On Lights for  
Use in Hazardous Locations**

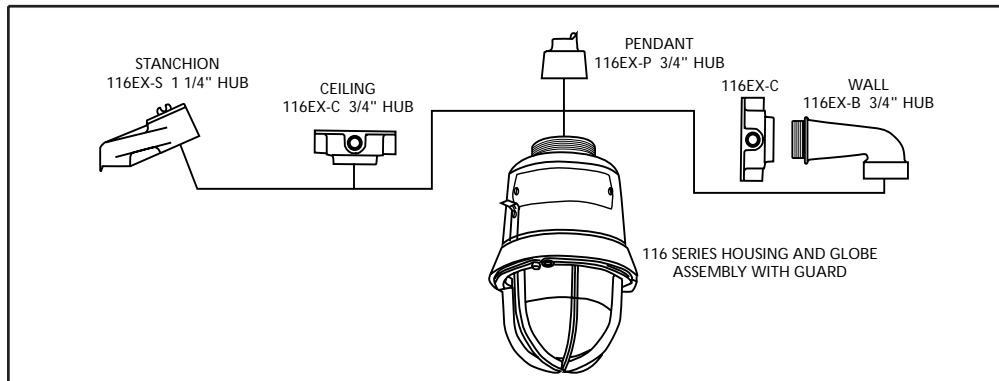

Figure 1. Mounting Options

**Description**

The 116DEXMSINH AdaptaBeacon 24-28V DC steady-on signaling appliances are heavy duty diode-polarized lights intended for use in general utility signaling (non-fire alarm) applications requiring electrical supervision of signaling circuit field wiring. The rotating assembly motor driven at approximately 60 rpm. These devices are UL and cUL listed for use in Class I, Division 1, Group C and D, Class I, Division 2, Group C and D, Class II, Divisions 1 and 2, Group F and G, Class II, Division 1, Group E, and Class III Division 1 and 2 hazardous locations with operating temperature codes per following chart.

They are UL and cUL Listed as Type 3R, 4X, and Marine enclosures.

The beacons are available with pendant, bracket, ceiling, or stanchion mounting modules. See Figure 1.

**Installation**

Install this unit in accordance with the applicable requirements in the latest edition of the National Electrical Code and Canadian Electrical Code.

**⚠ WARNING**  
To reduce the risks of ignition of hazardous atmospheres and shock, do not apply power to the unit until installation has been completed and unit is tightly assembled and secured.

1. Mount using the following applicable method.
  - a. **Pendant Mount Models** (Figure 2): Install the catalog number 116EX-P, pendant mounting module, to the main housing. Install explosion-proof hanger box (not supplied). Secure 3/4" (19

mm) NPT threaded conduit (not supplied) to the box. Install the unit on the conduit. Proceed to step 2.

- b. **Ceiling Mount Models** (Figure 3): Mount the catalog number 116EX-C, ceiling/wall mounting module, using appropriate hardware (not supplied) suitable for the mounting surface. Proceed to step 2.
- c. **Bracket Mount Models** (Figure 4): Install the catalog number 116EX-C ceiling/wall mounting module using appropriate hardware (not supplied) for the mounting surface. Install the catalog number 116EX-B wall mounting elbow to the wall box. Run the unit's wiring through the elbow to the wall box. Proceed to step 2.
- d. **Stanchion Mount Models** (Figure 5): Install the catalog number 116EX-S, stanchion mounting module, to the main housing. Run the unit's wires through the 1 1/4" conduit to the appropriate junction box. Install the unit on the conduit. Proceed to step 2.

2. Connect field earth ground wire to ground screw or earth ground via conduit system.
3. Wire the unit in accordance with Figure 6. See Table 2 for required supply wire temperature ratings.
4. As appropriate, install the fixture on the mounting module.

**⚠ WARNING**  
To reduce the risk of ignition of hazardous atmospheres and shock, keep assembly tightly closed when circuits are energized.

5. Apply power to the unit and ensure proper function.

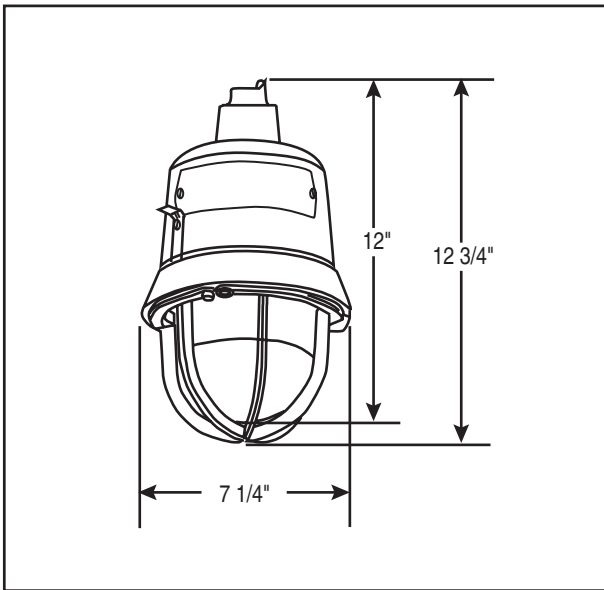

Figure 2. Detail of Pendant Mounting

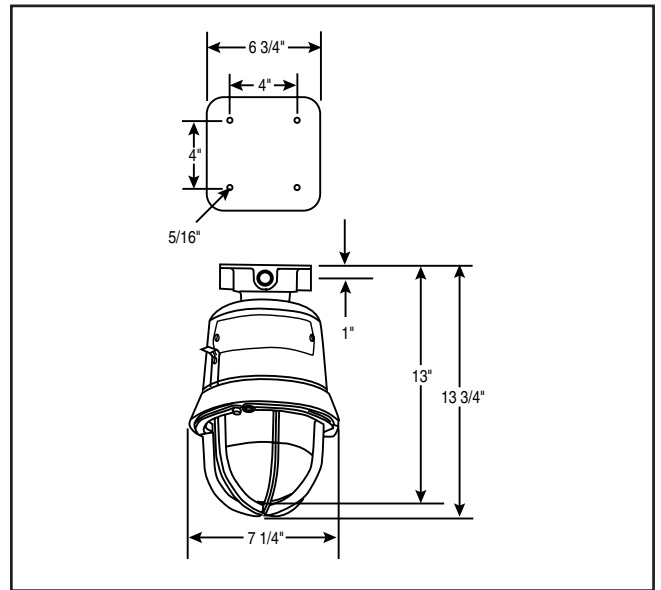

Figure 3. Detail of Ceiling Mounting

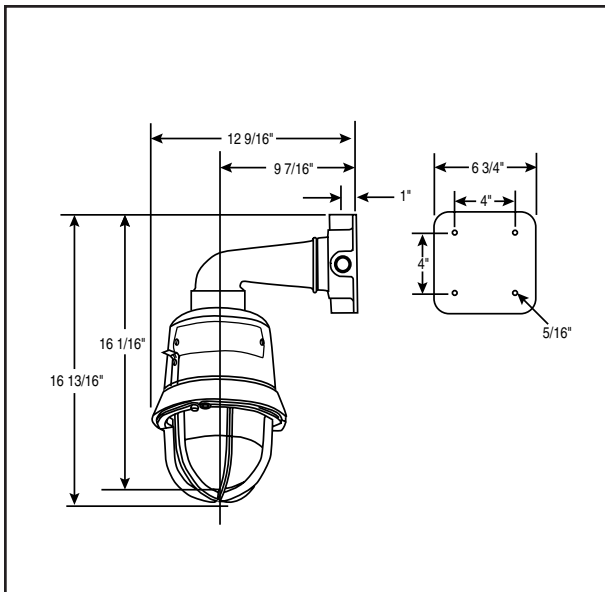

Figure 4. Detail of Wall Bracket Mounting

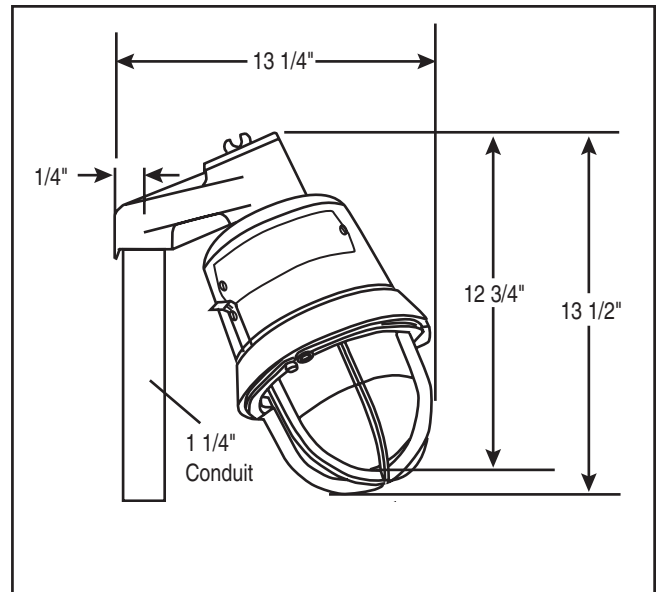

Figure 5. Detail of Stanchion Mounting

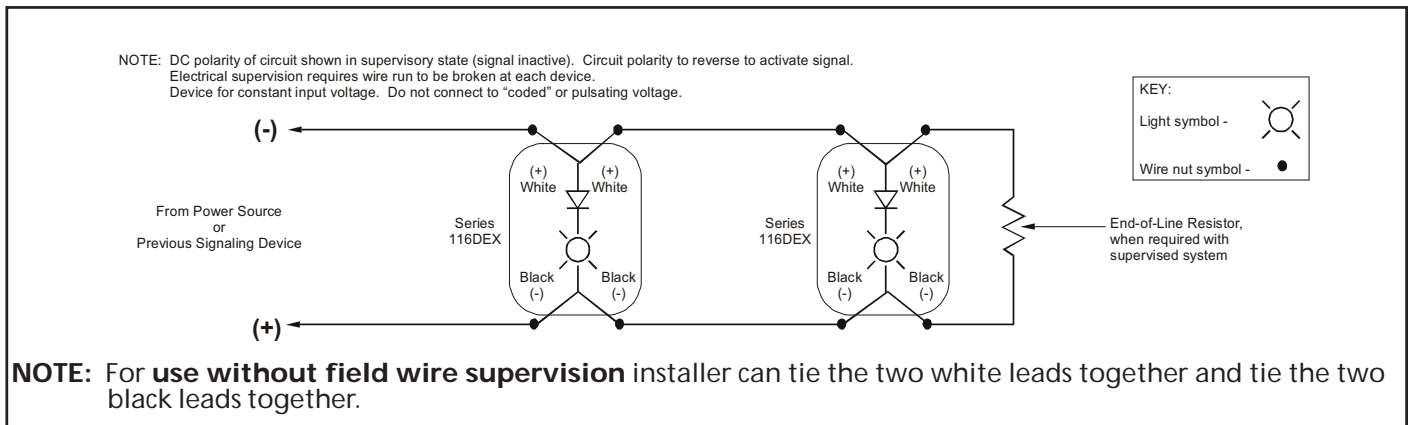

Figure 6. Wiring Diagram

## Maintenance

Disassemble the unit as follows (Figure 7):

**!** **WARNING**

**To reduce the risk of ignition of hazardous atmospheres and shock, keep assembly tightly closed when circuits are energized.**

**To reduce the risk of ignition of hazardous atmospheres and shock, disconnect from the supply and circuit and allow five (5) minutes for stored energy to dissipate before disassembling the unit.**

1. Loosen the (3) guard screws and remove the guard.
2. Loosen the globe and ring assembly set screw. Insert a suitable tool into the notches in the globe and ring assembly and loosen the assembly by prying in a

counterclockwise direction. Remove the ring and globe assembly.

3. Refer to Table 1 for the correct replacement catalog number and replace the necessary part.
4. To replace, simply screw the unit on until it seats firmly onto its gasket. Tighten the unit another 1/8 to 1/4 turn. Tighten the setscrew.
5. Reinstall the guard, where applicable, and secure using the three supplied screws.
6. After the unit is assembled, apply power and make sure the unit functions properly.

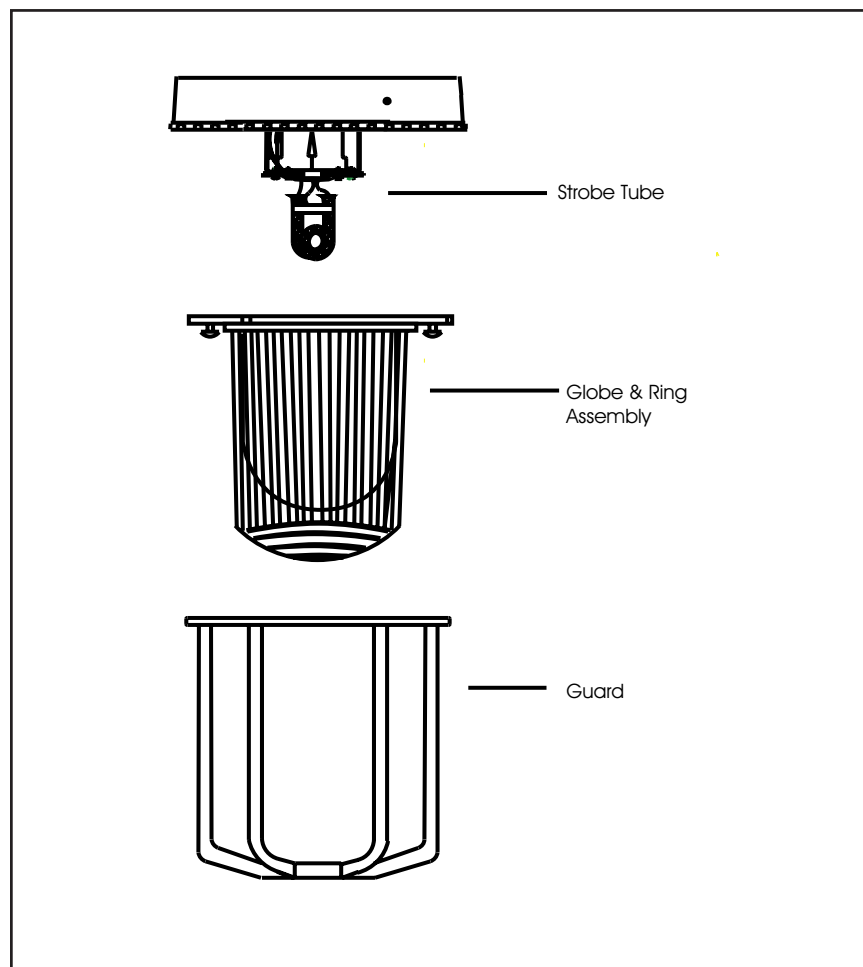

Figure 7. Disassembly of the 116EX Series AdaptaBeacons

Table 1. 116 Series AdaptaBeacons

Description	Catalog Number	Electrical Ratings	Conduit Size	Lamp Replacement
Beacon Less Mounting Module	116DEXMSINH*-GW	24 - 28V DC 0.8A	N/A	50LMP-20WH or Ind. Trade No. 25T8DC
Ceiling/Wall Mounting Module	116EX-C	N/A	3/4" NPT	N/A
Pendant Mounting Module	116EX-P	N/A	3/4" NPT	N/A
Stanchion Mounting Module	116EX-S	N/A	1 1/4" NPT	N/A
Wall Bracket Mounting Elbow	116EX-B	N/A	N/A	N/A

\*Letter in this position denotes color of the globe: A - amber, B - blue, C - clear, G - green, R - red or M - magenta

Table 2. Ratings

Ambient Temp.	Supply Wire Temp. Marking	Operating Temperature			
		Class I, Div. 2 Groups A, B	Class I, Div. 1 & 2 Groups C, D	Class II & III, Div. 1 Groups E, F, G	Class II & III, Div. 2 Group G
40°C	75°C	T3 (200°C)	T6 (85°C)	T4A (120°C)	T4A (120°C)
55°C	90°C	T3 (200°C)	T6 (85°C)	T4 (135°C)	T4 (135°C)
65°C	105°C	T2D (215°C)	T6 (85°C)	T4 (135°C)	T4 (135°C)